

INSTRUCTIONS

Risk Area Heat Detector with
Explosion-Proof Junction Box
Model HD



Table of Contents

DESCRIPTION	1
FEATURES	1
APPLICATIONS	2
IMPORTANT SAFETY NOTES	2
INSTALLATION	2
Detector Location	2
Mounting Surface	2
Detector Orientation	2
Protection Against Moisture Damage	3
Wiring Procedure	4
Junction Box Covers	8
STARTUP	9
Visual Inspection	9
Detector Operation Verification	9
System Operation Verification	9
MAINTENANCE	9
Calibration Verification	9
SPECIFICATIONS	10
DEVICE REPAIR AND RETURN	10
ORDERING INFORMATION	10
Model HD Model Matrix	11
APPENDIX A — FM APPROVAL DESCRIPTION	12
APPENDIX B — CSA APPROVAL DESCRIPTION	13
APPENDIX C — ATEX APPROVAL DESCRIPTION	14
APPENDIX D — IECEx APPROVAL DESCRIPTION	15
APPENDIX E — ADDITIONAL APPROVALS	16

Risk Area Heat Detector with Explosion-Proof Junction Box Model HD

DESCRIPTION

The Model HD Risk Area Heat Detector accurately senses the surrounding air temperature and actuates an electrical contact output at a pre-determined temperature. The expansion coefficients of the metal alloys used in the construction of the detector enable the hermetically sealed contact to activate at a precise point.

The Model HD Detector can be used as an alarm device to sense excessive heat or fire and warn personnel, or it can be used as a signaling device to sense fire and send a signal to an alarm panel for actuation of a fire suppression system.

The design of the heat detector utilizes Rate Compensation, which provides enhanced performance when compared to fixed-temperature or rate-of-rise detectors. Rate-of-rise devices rely on a rapid rate of increase in the ambient temperature to actuate an output and are subject to false alarms caused by warm thermal currents resulting from various industrial processes. Fixed temperature detectors must be completely heated to the alarm setpoint in order to activate and can require a longer than desired response time in the event of a rapidly growing fire. The Model HD Detector senses the surrounding air temperature and actuates its output when the temperature reaches the pre-determined level, regardless of the fire growth rate. The unique properties of the alloy outer shell allow the Model HD to respond more quickly as the fire growth rate increases; i.e., the faster the fire grows, the sooner the unit will react.

The heat detector and integral explosion-proof junction box have been properly evaluated and certified for high temperature exposure conditions. The detector's electrical contact is factory wired to a screw terminal block located within the junction box. All external wiring to the device is also connected to this screw terminal block. The junction box material type is available in



aluminum or stainless steel, with two or four conduit entries, and either 3/4 inch NPT or 25 mm threads.

The Model HD is ideally suited for use in hazardous (classified) locations.

FEATURES

- Repeatable - resets itself, nothing to replace, testable
- Rugged - withstands shock and vibration
- Versatile - various temperature settings available
- Economical - wide spacings reduce installation costs
- Factory set internal contact area is hermetically sealed in stainless steel
- Ease of wiring and installation
- Aluminum or stainless steel junction box, stainless steel heat detector
- Models approved and certified to FM, CSA, ATEX, IECEx, and INMETRO Hazardous Location standards
- Models certified by Exida for SIL 2 Safety Instrumented System applications

APPLICATIONS

- Turbine enclosures
- Confined spaces and dirty environments
- Fuel cells
- Gas compressors
- Hydraulic or lube pump locations
- Power generation
- Gas station islands
- Miscellaneous industrial processes
- Anywhere fire can occur

IMPORTANT SAFETY NOTES

WARNING

Do not open the junction box in a hazardous area when power is applied.

CAUTION

The wiring procedures in this manual are intended to ensure proper functioning of the device under normal conditions. However, because of the many variations in wiring codes and regulations, total compliance to these ordinances cannot be guaranteed. Be certain that all wiring complies with local ordinances. If in doubt, consult the authority having jurisdiction before wiring the system. Installation must be done by a properly trained person.

CAUTION

To prevent unwanted actuation or alarm, extinguishing devices must be disabled prior to performing system tests or maintenance.

CAUTION

The detectors are to be installed in places where the risk of mechanical damage is low.

NOTE

Repair of the internal and external threaded joints is not intended.

INSTALLATION

NOTE

The junction box must be electrically connected to earth ground. Internal and external earth ground terminals are provided. For AEx (United States Zone) installations, the internal ground terminal shall be used for the equipment grounding connection. The external terminal can be used for supplementary bonding where local codes permit or require.

DETECTOR LOCATION

Model HD detectors are precision temperature detectors. They must be mounted in an area (normally a ceiling) so that:

1. The detector spacing complies with both system requirements and requirements of the local agency having jurisdiction.
2. The thermal air path to the shell is not obstructed. Spacing per UL, FM, and ULC is shown in Table 1. Distances given are between units on smooth ceilings. Distances from partitions or walls are half that shown. To assure that all spacing requirements are met, consult the authority having jurisdiction.

MOUNTING SURFACE

The detector should be mounted to a solid surface that is not prone to high vibration, shock, traumatic impact, or other undesirable condition.

DETECTOR ORIENTATION

The Model HD detector is not position sensitive. The device can be mounted either horizontally or vertically depending on the application and installation requirements.

Table 1—Temperature Specifications and Maximum Detector Spacing Values

Setting ° F (° C)	Tolerance ° F (° C)	Spacings feet (meters)			RTI ¹	Color Coding ²
		UL	ULc	FM		
140 (60)	+7/-8 (±4)	50 (15)	50 (15)	25 (8)	Fast	Black
160 (71)	+7/-8 (±4)	25 (8)	25 (8)	25 (8)	Fast	Black
190 (88)	+7/-8 (±4)	50 (15)	50 (15)	25 (8)	Fast	White
210 (99)	+7/-8 (±4)	25 (8)	50 (15)	30 (9)	V- Fast	White
225 (107)	+7/-8 (±4)	25 (8)	50 (15)	30 (9)	V- Fast	White
275 (135)	±10 (±6)	25 (8)	50 (15)	30 (9)	V- Fast	Blue
325 (163)	±10 (±6)	50 (15)	50 (15)	30 (9)	V- Fast	Red
360 (182)	±10 (±6)	25 (8)	50 (15)	30 (9)	V- Fast	Red
450 (232)	±15 (±8)	25 (8)	50 (15)	30 (9)	V- Fast	Green
500 (260)	±15 (±8)	50 (15)	50 (15)	30 (9)	V- Fast	Orange
600 (316)	±20 (±11)	N/A	50 (15)	30 (9)	V- Fast	Orange
725 (385)	±20 (±11)	N/A	50 (15)	30 (9)	V- Fast	Orange

1 Response Time Index - Measurement of the Heat Detector's sensitivity and speed of response. For more information, refer to standards FM 3210 and EN 54-5.

2 Color of the printing on the detector.

PROTECTION AGAINST MOISTURE DAMAGE

It is important to take proper precautions during installation to ensure that moisture will not come in contact with the electrical connections or components of the system. The integrity of the system regarding moisture protection must be maintained for proper operation and is the responsibility of the installer.

NOTE

NEMA 4 / IP66 / IP67 rating requires the use of IP washers / IP glands (M25).

If conduit is used, we recommend installing drains, according to local codes, at water collection points to automatically drain accumulated moisture. It is also recommended to install at least one breather, according to local codes, at upper locations to provide ventilation and allow water vapor to escape.

Conduit raceways should be inclined so that water will flow to low points for drainage and will not collect inside enclosures or on conduit seals. If this is not possible, install conduit drains above the seals to prevent the collection of water or install a drain loop below the detector with a conduit drain at the lowest point of the loop.

Conduit seals are not required for compliance with explosion-proof installation requirements, but are highly recommended to prevent water ingress in outdoor applications. Units with M25 thread must use an IP66 washer to prevent water ingress.

NOTE

For optimum performance and maximum service life, care should be taken to protect the Model HD from corrosive contaminants in the atmosphere.

WIRING PROCEDURE

Wire Size and Type

The system should be wired according to local codes. The wire size selected should be based on the number of detectors connected, the supply voltage and the cable length. Typically 16 AWG, 2.5 mm² shielded cable is recommended. Wires should be stripped 3/8 inch, 9 mm.

The use of shielded cable is required to protect against interference caused by EMI and RFI. When using cables with shields, terminate the shields as shown in Figures 4 through 7, and Figures 9 through 12. Consult the factory if not using shielded cable.

In applications where the wiring cable is installed in conduit, the conduit must not be used for wiring to other electrical equipment.

If disconnection of power is required, separate disconnect capability must be provided.

WARNING

All entries must contain appropriately rated plugs or fittings. It is required that each plug or fitting be wrench-tightened to an appropriate installation torque and meet the minimum thread engagement requirements per the applicable local standards, codes, and practices in order to retain the defined ratings. PTFE sealant or equivalent should be used on NPT threads.

IMPORTANT

Devices certified for hazardous locations shall be installed in accordance with EN/IEC 60079-14 and NEC 505.

CAUTION

Installation of the detector and wiring should be performed only by qualified personnel.

Wiring Temperature Requirement

For ambient temperature above 60°C use field wiring suitable for maximum ambient temperature. For temperature below -10°C use field wiring suitable for the lowest temperature.

End-of-Line (EOL) and Short-Circuit-Monitoring (SCM) Resistors

To ensure that the insulating material of the wiring terminal block will not be affected by the heat generated by EOL and SCM resistors, observe the following guidelines when installing the resistors.

1. Required EOL and SCM resistor power rating must be 5 watts minimum and must be ceramic or wirewound type, with actual power dissipation not to exceed 2.5 watts.

NOTE

Refer to the Ordering Information section of this manual for information regarding EOL and SCM resistors. Use Det-Tronics parts or equivalent.

2. Resistor leads should be cut to a length of approximately 1 1/2 inches, 40 mm.
3. Bend the leads and install the EOL or SCM resistor as shown in Figure 1.
4. For Ex e installations, the EOL resistor must be located at the fire panel (refer to Figure 7). The SCM resistor is not to be used in Ex e installations.

NOTE

All cable entry devices and blanking elements shall be certified, suitable for the conditions of use, and correctly installed. Unused junction box entries must be closed with suitable and correctly installed plugs.

WARNING

Always ensure that the detector hazardous (classified) location ratings are applicable for the intended use.

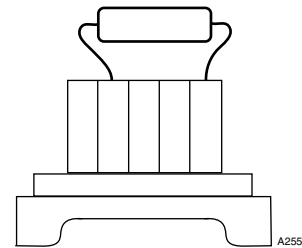

Figure 1—Resistor Installation

Detector Wiring

Figure 2 shows the wiring terminal strips within the junction box.

Figure 3 shows the recommended wiring connections for a single detector.

Figures 4 thru 7 show single detectors wired in a variety of typical configurations.

Figure 8 shows the wiring connections for daisy chained detectors.

Figures 9 thru 12 show daisy chained detectors wired in a variety of typical configurations.

1		10
2		9
3		8
4		7
5		6

2560

Figure 2—Wiring Terminal Identification

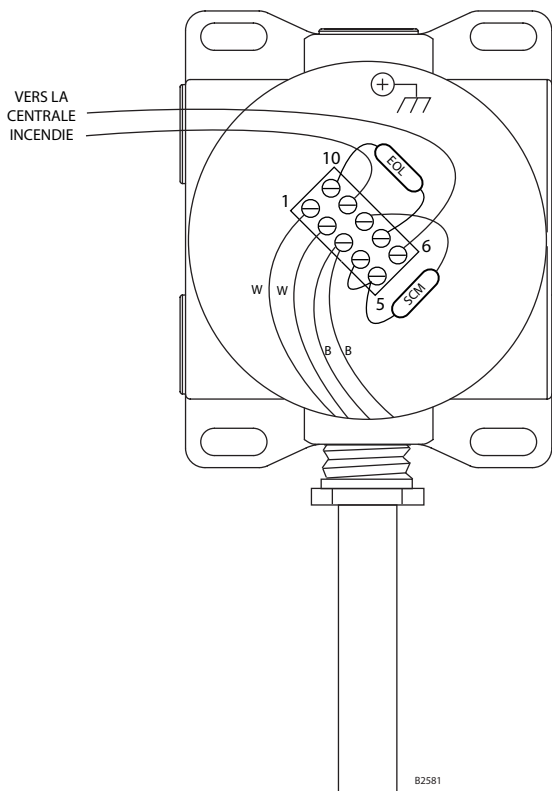

Figure 3—Recommended Ex d Wiring Connections - 2 Wire with Open and Short Circuit Monitoring

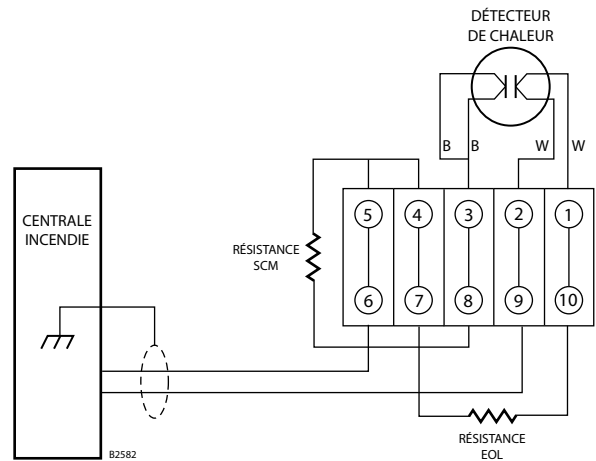

Figure 4—Typical Ex d Wiring - 2 Wire with Open and Short Circuit Monitoring

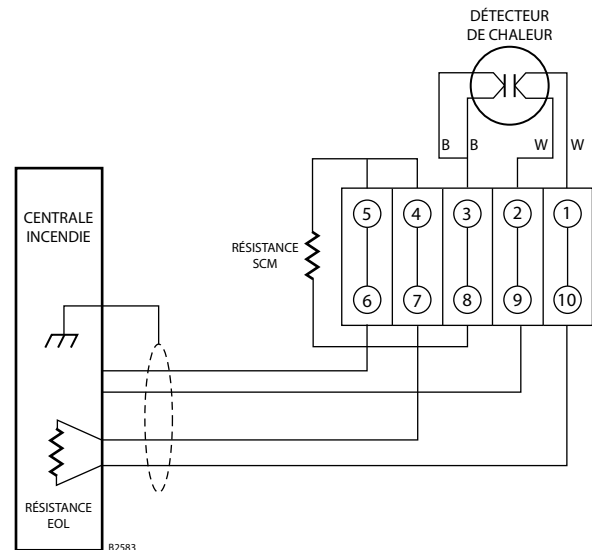

Figure 5—Typical Ex d Wiring - 4 Wire with Open and Short Circuit Monitoring

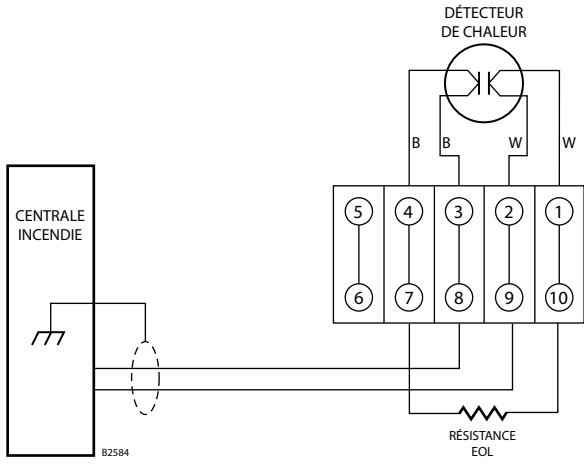

Figure 6— Typical Ex d Wiring - 2 Wire with Open Circuit Monitoring

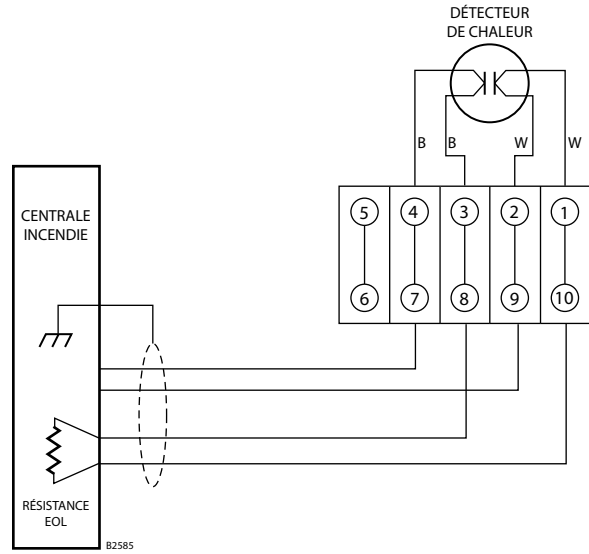

Figure 7— Typical Ex d e Wiring - 4 Wire with Open Circuit Monitoring

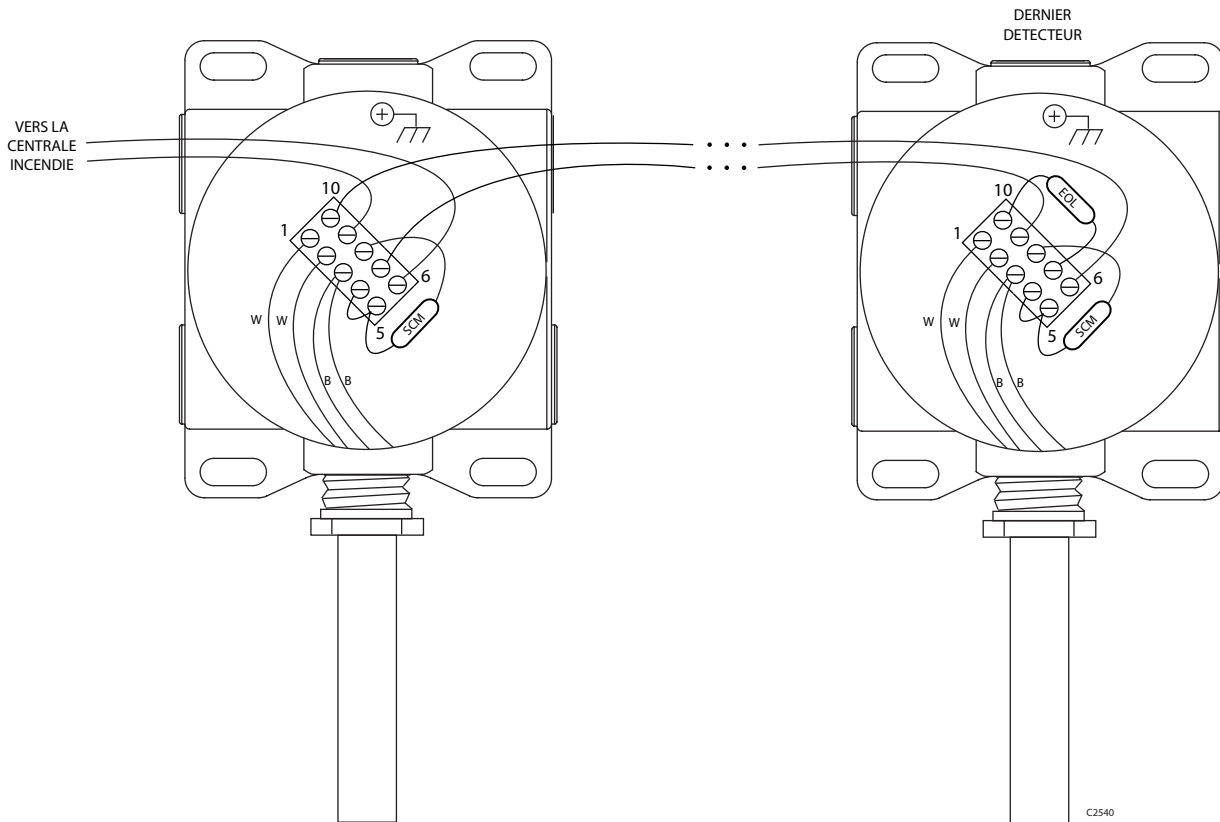

Figure 8—Optional Ex d Wiring Connections - 2 Wire with Open and Short Circuit Monitoring

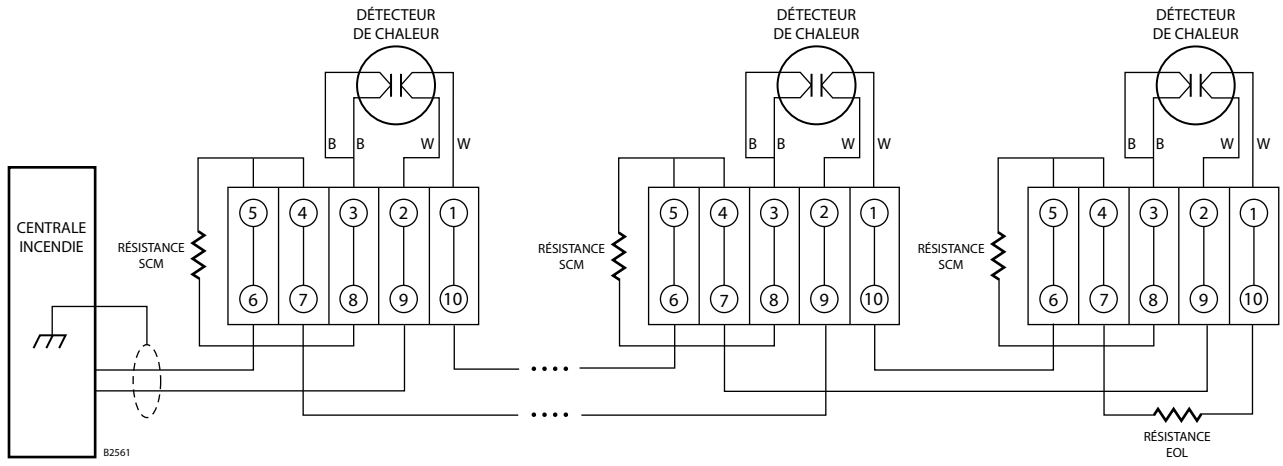

Figure 9—Typical Ex d Wiring - 2 Wire with Open and Short Circuit Monitoring

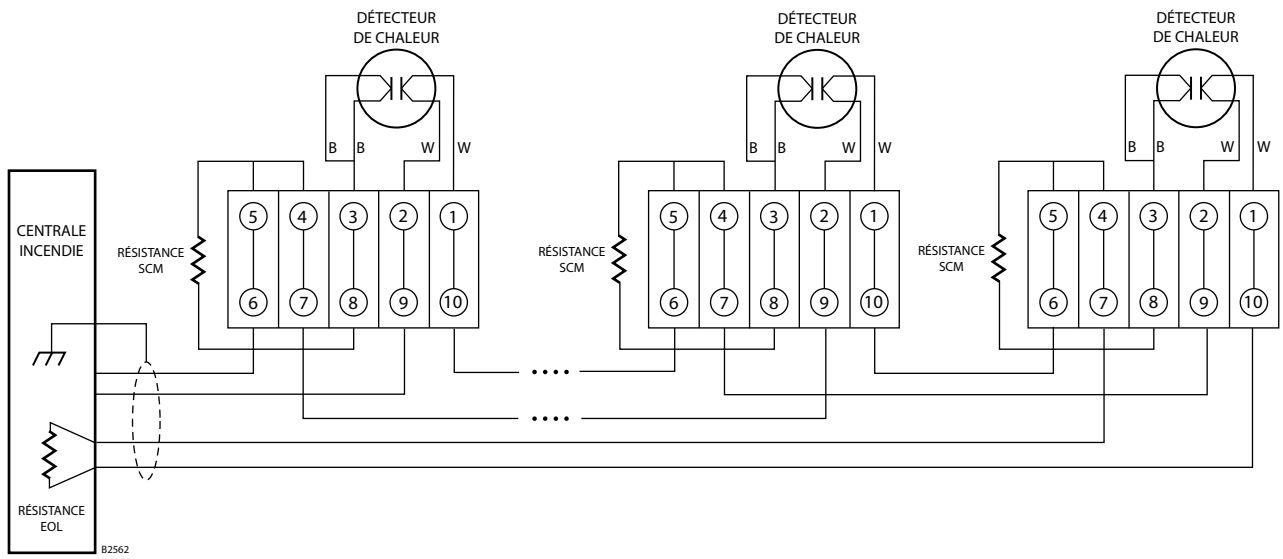

Figure 10—Typical Ex d Wiring - 4 Wire with Open and Short Circuit Monitoring

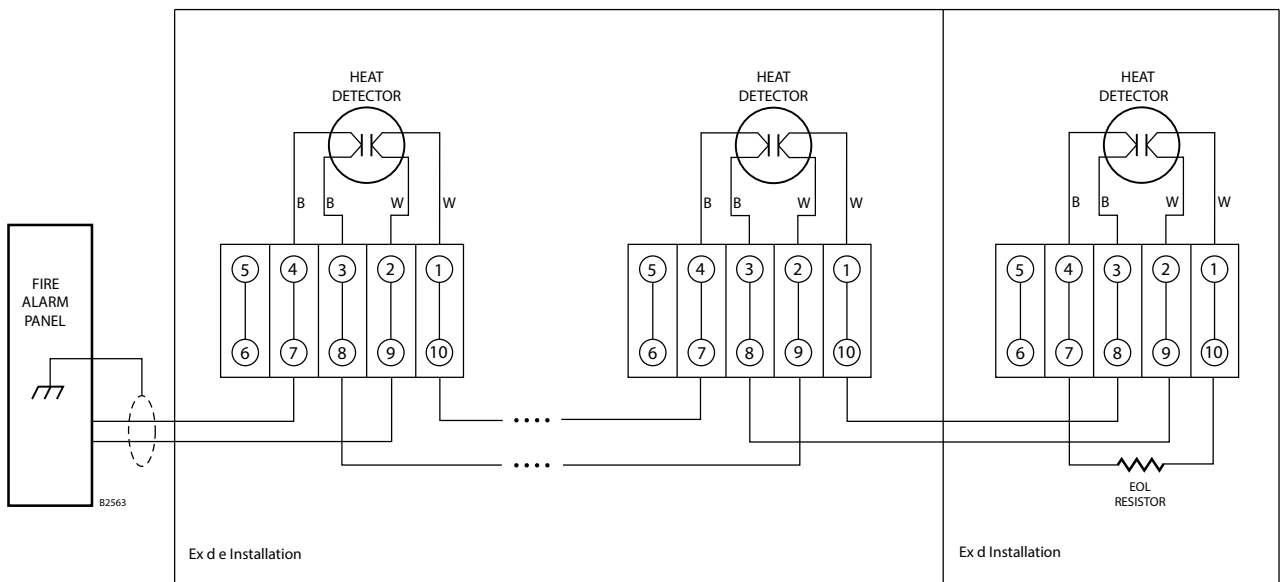

Figure 11—Typical Ex d and Ex d e Wiring - 2 Wire with Open Circuit Monitoring

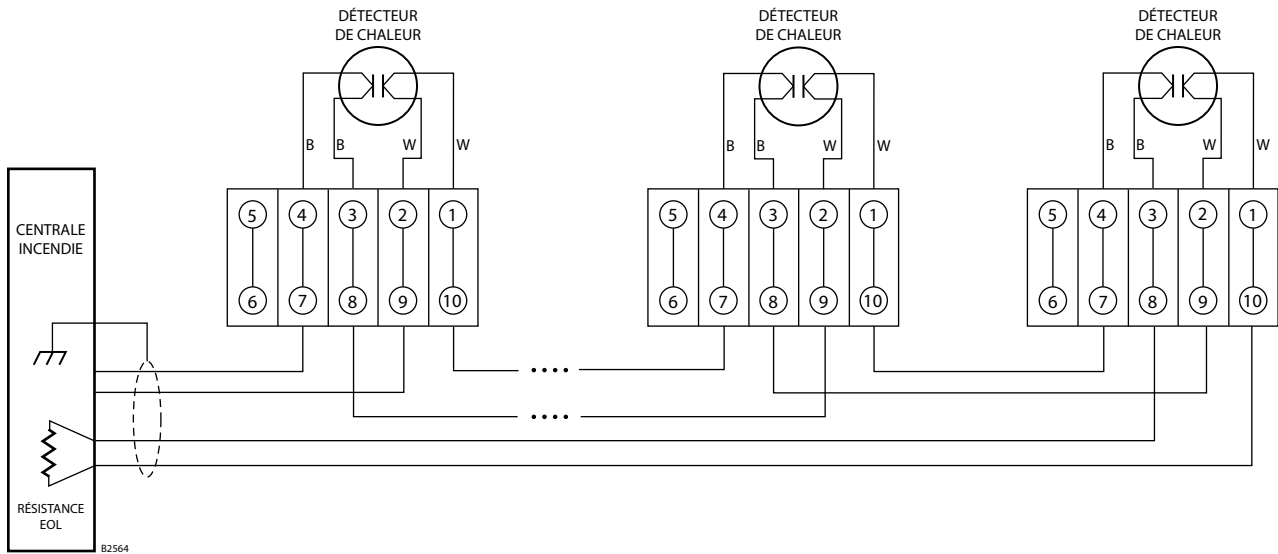

Figure 12—Typical Ex d e Wiring - 4 Wire with Open Circuit Monitoring

JUNCTION BOX COVERS

To ease installation and future removal, ensure that the threaded junction box covers are properly lubricated. If additional lubrication is required, use Lubriplate grease (see the “Ordering Information” section for part number).

When tightening the junction box cover, ensure that the O-ring is properly engaged.

The hex head set screw on the base of the junction box, located near port 2, should be tightened to secure the cover and prevent access to the wiring compartment without the use of a tool. See Figure 13 for location.

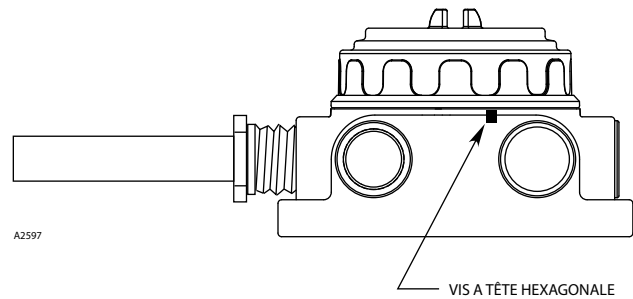

Figure 13—Location of Cover Locking Set Screw

STARTUP

WARNINGS

1. *DO NOT overshoot the setpoint of the unit by more than 100°F (55°C). This could result in a shift of the setpoint temperature.*
2. *DO NOT contact the sensing shell with a heating device such as a soldering iron or blowtorch, as this will damage the unit and cause a shift of the setpoint temperature.*
3. *Prior to performing any test, place the fire panel in Bypass/Inhibit to prevent actuation of deluge systems or other output devices.*
4. *The heat detectors are hermetically sealed and factory set, employing standard aluminum test blocks at the temperatures listed in the data sheet. A test kit with an aluminum block is required as it simulates factory test equipment. Heat transfer mediums such as liquid and air, or test equipment including air, liquid or sand baths are not recommended and should not be used for testing purposes.*
5. *The calibration verification procedures pertain to the heat detection element only.*
6. *While the detector is a repeatable device, replacement is recommended should the unit be subjected to the intense heat of a fire.*

VISUAL INSPECTION

The recommended maintenance procedure is to perform a visual inspection in accordance with NFPA 72 guidelines, EN 54 practice, and/or other applicable local requirements. During the visual inspection, verify that the sensing shell is free of dents, dings or build-up of foreign matter of any kind. If the shell is dented or shows signs of any physical damage, the unit should be replaced immediately. If the shell has been painted, the unit should be replaced. If a build-up of dust has accumulated on the unit, the unit may be cleaned with a vacuum or damp cloth. Care should be used not to damage the unit in any way.

DETECTOR OPERATION VERIFICATION

To verify the operation of individual detectors:

1. Remove power from the system.
2. Disconnect the detector from the system.
3. Connect an ohmmeter to the detector leads.
4. Apply heat evenly to the detector using an appropriate heat source.
5. Verify that the internal contacts close.
6. Remove the heat immediately after activation.
7. Allow all detectors to cool.
8. Re-connect the detectors to the system.
9. Restore power to the system.

SYSTEM OPERATION VERIFICATION

When used with automatic fire extinguishing systems:

1. Place the fire panel in Bypass/Inhibit mode.
2. Heat the detector with an appropriate heat source.
3. The panel annunciator must change state to indicate a successful detector test.
4. Remove the heat source from the detector.
5. Allow the detector to cool before resetting the panel.
6. When all detectors have been tested and have cooled below the setpoint, reset the system.
7. Place the fire panel back into Normal mode.

MAINTENANCE

The Model HD detector is a repeatable device with field proven reliability. Properly installed and applied, the device offers reliable, economical performance. Nonetheless, the units should be periodically checked for proper operation, following the procedures described in the Startup section of this manual. For additional information regarding maintenance of the detector, refer to the applicable standard.

CALIBRATION VERIFICATION

A special calibration test kit with a repeatable heat source is required to accurately determine the temperature setting of the detector. Please contact the Det-Tronics factory for information regarding suitable test kits.

CAUTION

Once the heat detector is exposed to flame, it is recommended to replace it with a new unit to maintain performance reliability.

SPECIFICATIONS

TERMINALS—

UL/CSA rated for 12–26 AWG, 2.5–1.5 mm² wire. Screw terminal required torque range is 3.5–5.3 in.-lbs. (0.4–0.6 N•m).

ELECTRICAL RATING—

Open circuit monitoring:

1.0 Amp maximum @ 30 Vdc (resistive).

Open & short circuit monitoring:

1.0 Amp maximum @ 30 Vdc (resistive).

AMBIENT TEMPERATURE RANGE—

Operating: -40°F to +257°F (-40°C to +125°C).

Storage: -40°F to +257°F (-40°C to +125°C).

TEMPERATURE PERFORMANCE RANGE—

Refer to the Model Matrix in the “Ordering Information” section of this manual.

HUMIDITY RANGE—

5 to 95% RH, non-condensing.

THREAD OPTIONS—

3/4 inch NPT or M25.

Two or four port models available.

Note: NEMA 4 / IP66 / IP67 rating requires the use of IP washers / IP glands (M25).

DIMENSIONS—

See Figure 14.

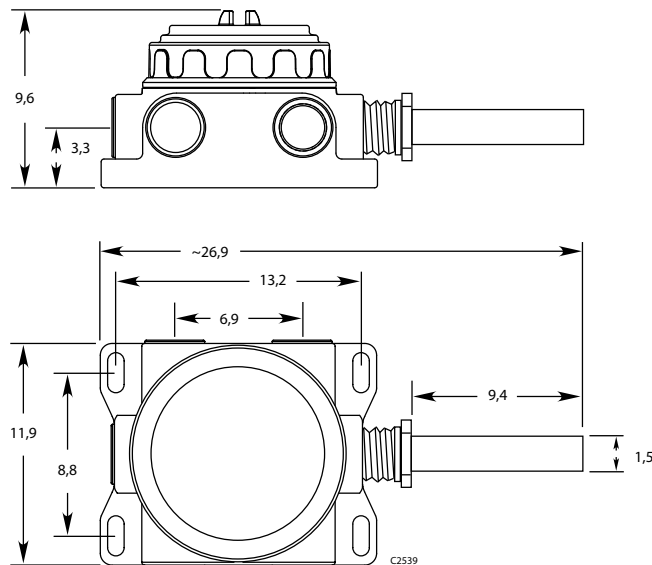

Figure 14—Dimensions of Heat Detector in Inches (cm)

CERTIFICATION—

For complete approval details, refer to the appropriate Appendix:



Appendix A – FM

Appendix B – CSA

Appendix C – ATEX

Appendix D – IECEx

Appendix E – Additional Approvals

DEVICE REPAIR AND RETURN

Prior to returning devices, contact the nearest local Detector Electronics office so that a Return Material Authorization (RMA) number can be assigned. **A written statement describing the malfunction must accompany the returned device or component to assist and expedite finding the root cause of the failure.**

Pack the unit properly. Always use sufficient packing material. Where applicable, use an antistatic bag as protection from electrostatic discharge.

NOTE

Det-Tronics reserves the right to apply a service charge for repairing returned product damaged as a result of improper customer packaging.

Return all equipment via transportation prepaid to the factory in Minneapolis.

NOTE

It is highly recommended that a spare detector be kept on hand for field replacement to ensure continuous protection.

ORDERING INFORMATION

When ordering, please specify:

Model HD Risk Area Heat Detector with Explosion-Proof Junction Box

Refer to the Model Matrix for details.

ACCESSORIES/SPARE PARTS

Part Number Description

104372-154	O-ring, FKM - black or brown
012549-001	1 oz PTFE silicone-free lubricant
104106-001	End-of-Line Resistor, 10k Ω \pm 1%, 5 watt wirewound
101118-XXX	Short Circuit Monitoring Resistor, 500 Ω - 3.3K Ω \pm 1%, 5 watt wirewound
101197-001*	Stop Plug, 3/4" NPT, Aluminum
101197-003**	Stop Plug, M25, Stainless Steel
101197-004*	Stop Plug, 3/4" NPT, Stainless Steel
101197-005**	Stop Plug, M25, Aluminum

Part Number Description

104190-001	Stop Plug, M25, Aluminum, IP66, INMETRO
104190-002*	Stop Plug, 3/4" NPT, Aluminum, INMETRO
104190-003	Stop Plug, M25, Stainless Steel, IP66, INMETRO
104190-004*	Stop Plug, 3/4" NPT, Stainless Steel, INMETRO

*Note: IP66/67 rating requires the use of Teflon tape (3/4" NPT).

**Note: For use in -20°C to +80°C temperature range only.

MODEL HD RISK AREA HEAT DETECTOR MODEL MATRIX

MODEL	DESCRIPTION	
HD	Risk Area Heat Detector	
	TYPE	SETTING
	140	140° F (60° C)
	160	160° F (71° C)
	190	190° F (88° C)
	210	210° F (99° C)
	225	225° F (107° C)
	275	275° F (135° C)
	325	325° F (163° C)
	360	360° F (182° C)
	450*	450° F (232° C)
	500*	500° F (260° C)
	600*	600° F (316° C)
	725*	725° F (385° C)
	TYPE	MATERIAL
	A	Aluminum
	S	Stainless Steel (316)
	TYPE	THREAD TYPE
	2M	2 Port, Metric M25
	2N	2 Port, 3/4" NPT
	4M	4 Port, Metric M25
	4N	4 Port, 3/4" NPT
	TYPE	OUTPUTS
	11	Contact Closure
	TYPE	APPROVALS**
	T	SIL/FM/CSA/ATEX/IECEX
	A	FM/CSA
	B	INMETRO (Brazil)
	S	SIL
	TYPE	CLASSIFICATION (Div/Zone)
	1	Div/Zone Ex d e
	2	Div/Zone Ex d

* Setting only available with Approvals Type A Division Classification.

**Type Approvals can use one or more letters to designate the approvals of the product.

APPENDIX A

FM APPROVAL DESCRIPTION

Class I, Div. 1, Groups B, C & D (T4)
Class I, Div. 2, Groups A, B, C & D (T3A)
Class II/III, Div. 1/Div. 2, Groups E, F, & G (T4)
Tamb = -40°C to +125°C
Enclosure Type 4X
IP66/IP67
Conduit seal not required.

APPLICABLE REQUIREMENTS

FM 3600 Electrical Equipment for use in Hazardous (Classified) Locations
FM 3611 Non-incendive Electrical Equipment for Use in Class I and II, Division 2, and Class III, Division 1 and 2, Hazardous (Classified) Locations
FM 3615 Explosion-proof Electrical Equipment
FM 3810 Electrical Equipment for Measurement, Control and Laboratory Use
FM 3210 Heat Detectors for Automatic Fire Alarm Signaling
ANSI/IEC 60529 Degrees of Protection Provided by Enclosures (IP Code)
ANSI/NEMA 250 Enclosures for Electrical Equipment (1000 Volts Maximum)

Flameproof per ANSI/ISA 60079-0, -1, -7, -31
CL I, ZONE 1, AEx db eb IIC T4
T4 (Tamb -40°C to +75°C)
ZONE 21, AEx tb IIIC T85°C
Tamb -40°C to +75°C
IP66/IP67

CL I, ZONE 1, AEx db IIC T4
T4 (Tamb -40°C to +125°C)
ZONE 21, AEx tb IIIC T135°C
Tamb -40°C to +125°C
IP66/IP67

The following accessories are FM approved for use with the Model HD Risk Area Heat Detector:

Part Number	Description
101197-001*	Stop Plug, 3/4" NPT, Aluminum
101197-003	Stop Plug, M25, Stainless Steel (-20°C to +80°C)
101197-004*	Stop Plug, 3/4" NPT, Stainless Steel
101197-005	Stop Plug, M25, Aluminum (-20°C to +80°C)

*IP66/67 rating requires the use of Teflon tape (3/4" NPT).

Stop Plugs

Det-Tronics offers M25 and 3/4 inch NPT stop plugs that have been approved for use with the Model HD. When using any of the stop plugs listed under "Ordering Information," it is required that each plug be tightened to an installation torque of 35 ft-lb (47.5 N-m) and meet the minimum thread engagement requirements per the applicable standards in order to retain the IP66/IP67 rating.

APPENDIX B

CSA APPROVAL DESCRIPTION

DIVISION CLASSIFICATION

CLASS 4818 04 - SIGNAL APPLIANCES - Systems - For Hazardous Locations

Class I, Div. 1, Groups B, C & D (T4)

Class I, Div. 2, Groups A, B, C & D (T3A)

Class II/III, Div. 1/Div. 2, Groups E, F, & G (T4)

Tamb = -40°C to +125°C

Enclosure Type 4X

IP66/IP67

Conduit seal not required

APPLICABLE REQUIREMENTS

CAN/CSA-C22.2 No. 25-1966	Enclosures for Use in Class II, Groups E, F and G Hazardous Locations
CAN/CSA-C22.2 No. 30-M1986	Explosion-Proof Enclosures for Use in Class I Hazardous Locations
CAN/CSA-C22.2 No. 94-M91	Special Purpose Enclosures
CAN/CSA-C22.2 No. 142-M1987	Process Control Equipment
CAN/CSA-C22.2 No. 213-16	Non-incendive Electrical Equipment for Use in Class I, Division 2 Hazardous Locations
CAN/CSA-C22.2 No. 0-10	General requirements – Canadian Electrical Code, Part II
CAN/CSA-C22.2 No. 60529:16	Degrees of protection provided by enclosures (IP Code)

ZONE CLASSIFICATION:

CLASS 4818 04 - SIGNAL APPLIANCES - Systems - For Hazardous Locations

Ex db eb IIC T4

T4 (Tamb = -40°C to +75°C)

IP66/IP67

Ex db IIC T4

T4 (Tamb = -40°C to +125°C)

IP66/IP67

APPLICABLE REQUIREMENTS

CAN/CSA-C22.2 No. 60079-0: 2015	–	Electrical apparatus for explosive atmospheres. Part 0: General requirements
CAN/CSA-C22.2 No. 60079-1: 2016	–	Explosive atmospheres. Part 1: Equipment protection by flameproof enclosures “d”
CAN/CSA-C22.2 No. 60079-7: 2012	–	Explosive atmospheres. Part 7: Equipment protection by increased safety “e”

The following accessories are CSA approved for use with the Model HD Risk Area Heat Detector:

Part Number	Description
101197-001*	Stop Plug, 3/4" NPT, Aluminum
101197-003	Stop Plug, M25, Stainless Steel (-20°C to +80°C)
101197-004*	Stop Plug, 3/4" NPT, Stainless Steel
101197-005	Stop Plug, M25, Aluminum (-20°C to +80°C)

*IP66/67 rating requires the use of Teflon tape (3/4" NPT).

Stop Plugs

Det-Tronics offers M25 and 3/4 inch NPT stop plugs that have been approved for use with the Model HD. When using any of the stop plugs listed under “Ordering Information,” it is required that each plug be tightened to an installation torque of 35 ft-lb (47.5 N·m) and meet the minimum thread engagement requirements per the applicable standards in order to retain the IP66/IP67 rating.

APPENDIX C

ATEX APPROVAL DESCRIPTION

CE 0539  II 2 G D
 FM12ATEX0032X
 Ex db eb IIC T4 Gb
 Ex tb IIIC T85°C Db
 T4 (Tamb –40°C to +75°C)
 IP66/67

--OR--

CE 0539  II 2 G D
 FM12ATEX0032X
 Ex db IIC T4 Gb
 Ex tb IIIC T135°C Db
 T4 (Tamb –40°C to +125°C)
 IP66/67

Compliance with:

EN 60079-0:2012+A11:2013	Explosive atmospheres – Part 0: Equipment – General requirements
EN 60079-1:2014	Explosive atmospheres – Part 1: Equipment protection for flameproof enclosures “d”
EN 60079-7:2015	Explosive atmospheres – Part 7: Equipment protection by increased safety “e”
EN 60079-31:2014	Explosive atmospheres – Part 31: Equipment dust ignition protection by enclosure “t”
EN 60529:1991+A1:2000+A2:2013	Degrees of Protection Provided by Enclosures (IP Code)

The following accessories are ATEX approved for use with the Model HD Risk Area Heat Detector:

Part Number	Description
101197-001*	Stop Plug, 3/4” NPT, Aluminum Gb
101197-003	Stop Plug, M25, Stainless Steel (–20°C to +80°C) Gb
101197-004*	Stop Plug, 3/4” NPT, Stainless Steel Gb
101197-005	Stop Plug, M25, Aluminum (–20°C to +80°C) Gb

*IP66/67 rating requires the use of Teflon tape (3/4” NPT).

Stop Plugs

Det-Tronics offers M25 and 3/4 inch NPT stop plugs that have been approved for use with the Model HD. When using any of the stop plugs listed under “Ordering Information,” it is required that each plug be tightened to an installation torque of 35 ft-lb (47.5 N-m) and meet the minimum thread engagement requirements per the applicable standards in order to retain the IP66/IP67 rating.

Special conditions for safe use:

The painted surface of the enclosure may cause an electrostatic spark. To prevent the risk of electrostatic sparking, the painted surfaces should only be cleaned with a damp cloth.

Repair of the internal and external threaded joints is not intended.

APPENDIX D

IECEX APPROVAL DESCRIPTION

IECEX FMG 13.0009X
Ex db IIC T4 Gb
Ex tb IIIC T135°C Db
T4 (Tamb –40°C to +125°C)
IP66/67

--OR--

IECEX FMG 13.0009X
Ex db eb IIC T4 Gb
Ex tb IIIC T85°C Db
T4 (Tamb –40°C to +75°C)
IP66/67

Compliance with:

IEC 60079-0:2011	Explosive atmospheres – Part 0: Equipment – General requirements
IEC 60079-1:2014	Explosive atmospheres – Part 1: Equipment protection for flameproof enclosures “d”
IEC 60079-7:2015	Explosive atmospheres – Part 7: Equipment protection by increased safety “e”
IEC 60079-31:2013	Explosive atmospheres – Part 31: Equipment dust ignition protection by enclosure “t”
IEC 60529:2013	Degrees of Protection Provided by Enclosures (IP Code)

The following accessories are IECEx approved for use with the Model HD Risk Area Heat Detector:

Part Number	Description
101197-001*	Stop Plug, 3/4" NPT, Aluminum Gb
101197-003	Stop Plug, M25, Stainless Steel (–20°C to +80°C) Gb
101197-004*	Stop Plug, 3/4" NPT, Stainless Steel Gb
101197-005	Stop Plug, M25, Aluminum (–20°C to +80°C) Gb

*IP66/67 rating requires the use of Teflon tape (3/4" NPT).

Stop Plugs

Det-Tronics offers M25 and 3/4 inch NPT stop plugs that have been approved for use with the Model HD. When using any of the stop plugs listed under “Ordering Information,” it is required that each plug be tightened to an installation torque of 35 ft-lb (47.5 N·m) and meet the minimum thread engagement requirements per the applicable standards in order to retain the IP66/IP67 rating.

Special conditions for safe use:

The painted surface of the enclosure may cause an electrostatic spark. To prevent the risk of electrostatic sparking, the painted surfaces should only be cleaned with a damp cloth.

Repair of the internal and external threaded joints is not intended.

APPENDIX E

ADDITIONAL APPROVALS

SIL 2



IEC 61508

Certified SIL 2 Capable.

Applies to specific models - refer to the SIL 2 Certified HD Safety Manual, number 95-8740, for details.

INMETRO

UL-BR 15.0409X
Ex tb IIIC T85°C Db
T4 (Tamb -40°C to +75°C)
IP66/67

--OR--

UL-BR 15.0409X
Ex tb IIIC T135°C Db
T4 (Tamb -40°C to +125°C)
IP66/67

All cable entry devices shall be Brazil certified in the type of explosion protection, flameproof enclosure 'd', suitable for the conditions of use and correctly installed, with an ingress protection rating of IP66.

A screw or cover lock is provided for a secondary means of fastening the cover.

Special conditions for safe use:

- The painted surface of the enclosure may cause an electrostatic spark. To prevent the risk of electrostatic sparking, the painted surface should only be cleaned with a damp cloth.
- For ambient temperatures below -10°C and above +60°C, use wiring/cables suitable for both minimum and maximum ambient temperature.

The following accessories are INMETRO approved for use with the Model HD Risk Area Heat Detector:

Part Number	Description
104190-001	Stop Plug, M25, Aluminum, IP66
104190-002*	Stop Plug, 3/4" NPT, Aluminum
104190-003	Stop Plug, M25, Stainless Steel, IP66
104190-004*	Stop Plug, 3/4" NPT, Stainless Steel

*IP66/67 rating requires the use of Teflon tape (3/4" NPT).

Stop Plugs

Det-Tronics offers M25 and 3/4 inch NPT stop plugs that have been approved for use with the Model HD. When using any of the stop plugs listed under "Ordering Information," it is required that each plug be tightened to an installation torque of 35 ft-lb (47.5 N·m) and meet the minimum thread engagement requirements per the applicable standards in order to retain the IP66/IP67 rating.



95-8666



FlexSonic™ Acoustic
Leak Detector



X3301 Multispectrum
IR Flame Detector



PointWatch Eclipse® IR
Combustible Gas Detector



FlexVu® Universal Display
with GT3000 Toxic Gas Detector



Eagle Quantum Premier®
Safety System

Corporate Office
6901 West 110th Street
Minneapolis, MN 55438 USA
www.det-tronics.com

Phone: 952.946.6491
Toll-free: 800.765.3473
Fax: 952.829.8750
det-tronics@det-tronics.com

All trademarks are the property of their respective owners.
© 2019 Detector Electronics Corporation. All rights reserved.
Det-Tronics manufacturing system is certified to ISO 9001—
the world's most recognized quality management standard.

